

WDB Bearing Temperature Sensors

ATEX-Approved for for dust-explosive environments
Zones 20, 21 & 22

APPLICATION

Bearing Temperature Sensors with thermistors type PTC, NTC, or PT100 (PTC 80°C stocked as standard - other temperatures available on request)

FEATURES

- ▶ Easy installation; sensors screw into existing bearing grease nipple
- ▶ Bearing sensors can be used with the control modules T400 ELITE or WATCHDOG ELITE & T500 ELITE, all ATEX-certified
- ▶ Standard supply: 12 Vdc or 24 Vdc
- ▶ Certified for ATEX Zone 20 Ex II 1D T125°C IP65 – ZONE 20 & CSA Class 2, Div. 1, Groups E, F & G

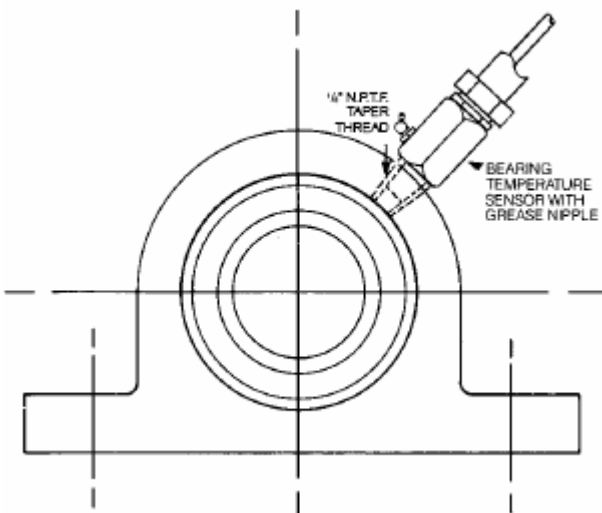

Installation of bearing temperature sensor

Detailed specification, wiring diagrams and installation/operating instructions available immediately upon request.

WDB24V3CA steel body
Conduit entry



WDB14V3A bronze body
Cable entry



ATEX-Approved
Ex II 1D T100°C
-IP 65-ZONE 20



CLASS 2 Div. 1
Groups E, F & G

Please refer to instruction manual for correct installation .
Information subject to change or correction. July 2007.



**WDB1 series bronze body
Cable entry**



**WDB2 series steel body
Conduit entry**

Part No	Type	Temperature
WDB10V3A	NTC	125°C
WDB11V3A	PTC	50°C
WDB12V3A	PTC	60°C
WDB13V3A	PTC	70°C
WDB14V3A	PTC	80°C
WDB15V3A	PTC	90°C
WDB16V3A	PTC	100°C
WDB17V3A	PTC	110°C
WDB18V3A	PTC	120°C
WDB40V3A	PT100	X

Part No	Type	Temperature
WDB20V3CA	NTC	125°C
WDB21V3CA	PTC	50°C
WDB22V3CA	PTC	60°C
WDB23V3CA	PTC	70°C
WDB24V3CA	PTC	80°C
WDB25V3CA	PTC	90°C
WDB26V3CA	PTC	100°C
WDB27V3CA	PTC	110°C
WDB28V3CA	PTC	120°C
WDB50V3A	PT100	X

Bearing sensors can be used with the following 4B Monitoring Systems

T500 ELITE



T400 ELITE



WATCHDOG ELITE



ZONES 21 & 22

Please refer to instruction manual for correct installation .
Information subject to change or correction. July 2007.